

Quick Star Quilts

Assembly tips – Powerpoint screen shots

After optional trim strip is added to the diamond edges...

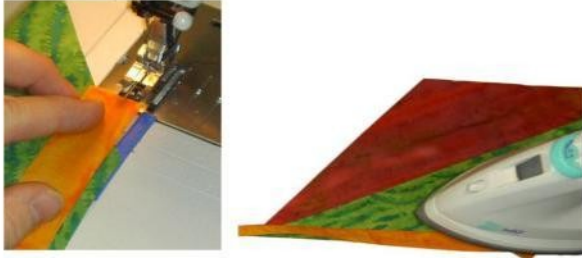

1

...and excess trimmed to match diamond edges...

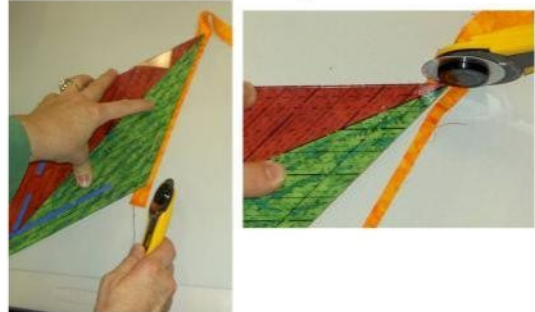

2

...remember to fold back fabric at the tip and trim interior scraps...



3

Mark diamonds, squares & triangles with 1/4" seam allowances...

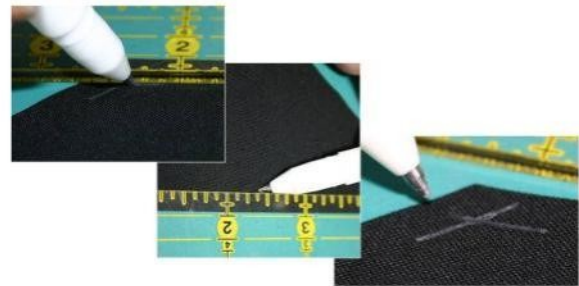

4

... as indicated on the quilt diagram with dots.

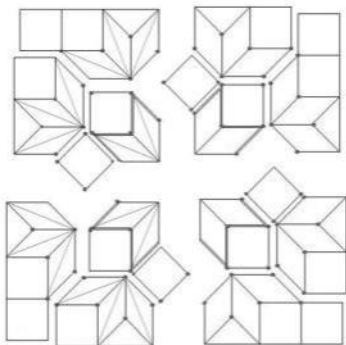

5

It is unnecessary to mark the outer edges of squares, or triangle pointy tips

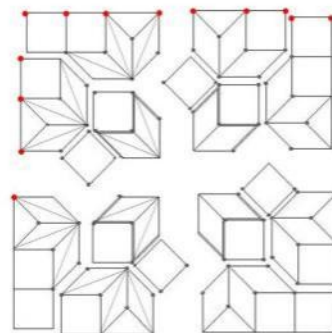

6

Quick Star Quilts

Assembly tips – Powerpoint screen shots

Study the quilt diagram.
Assemble the quilt in sections.

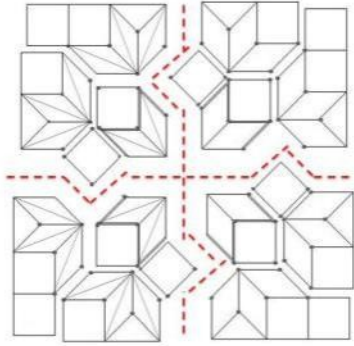

7

Locate the duplicate quilt diagram in your
handout.

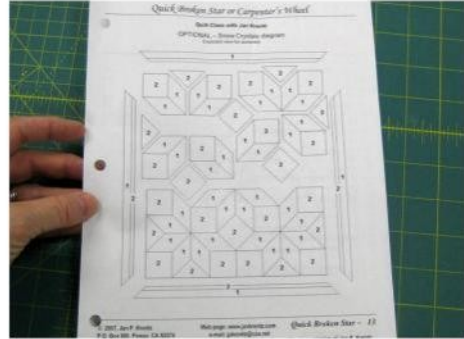

8

I have provided a duplicate sheet *with*
the pressing arrows.

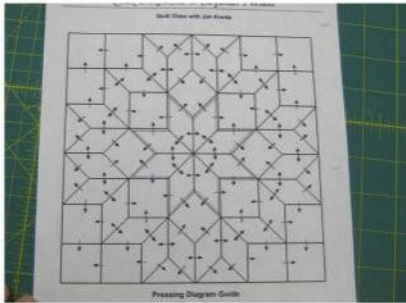

9

Cut apart the duplicate quilt diagram, one
section at a time.



10

Pin the small paper pattern to the
corresponding DIAMOND on the design wall



11

Construct outer sections first

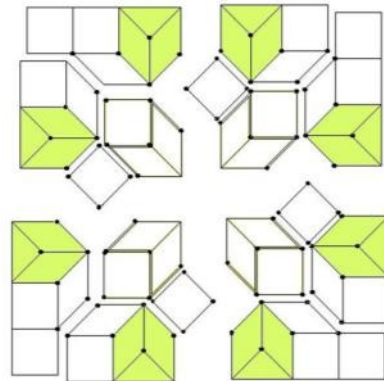

12

Quick Star Quilts

Assembly tips – Powerpoint screen shots

Mark the corners of the triangles, and the edges of the diamonds.

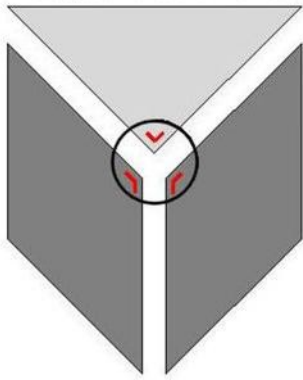

13

Flip the triangle right sides together onto the left diamond.

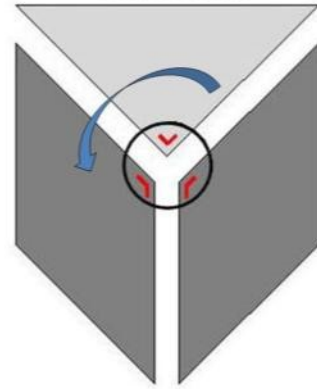

14

The shape of both the diamond and the triangle will align....

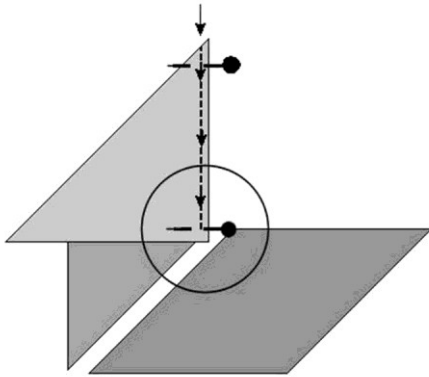

15

Begin stitching at the RAW EDGE and back-tack....

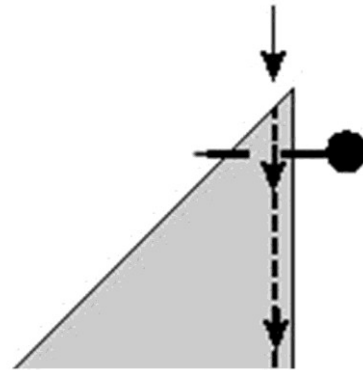

16

Sew the seam down to the pencil mark, stop & back-tack....

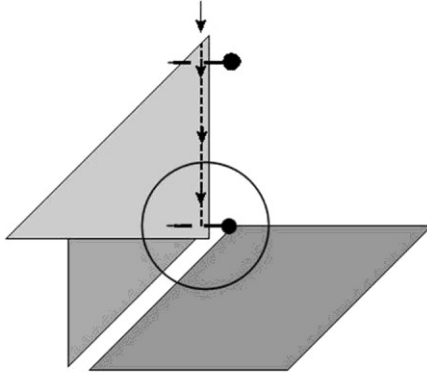

17

Sew the seam down to the pencil mark, stop & back-tack....

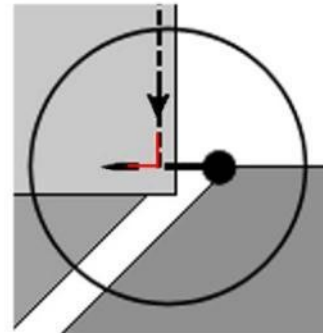

18

Quick Star Quilts

Assembly tips – Powerpoint screen shots

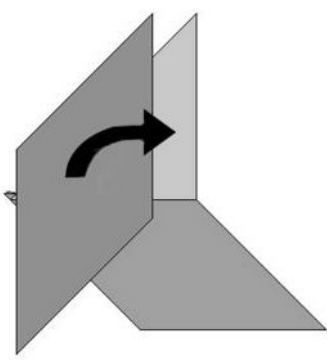
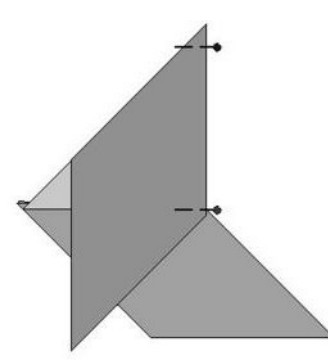
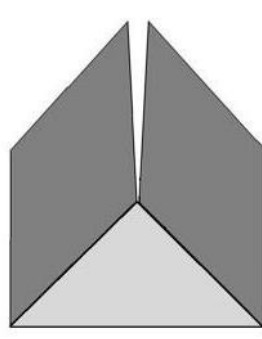
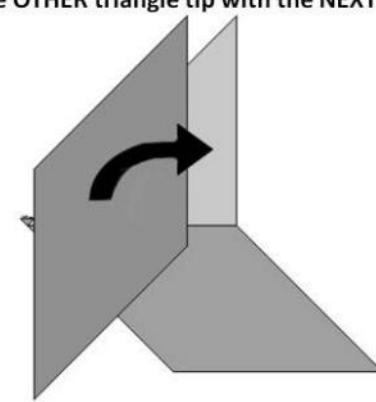
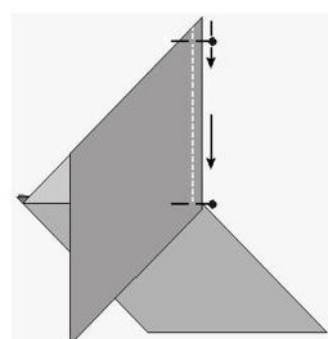
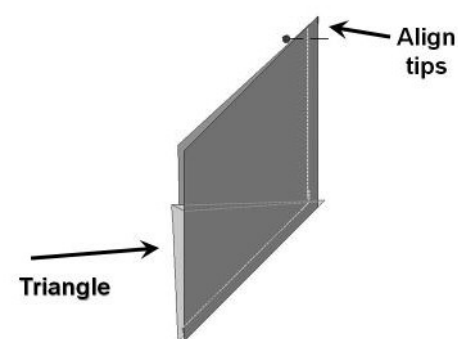
<p>19</p> <p>Remove from the machine.</p> 	<p>20</p> <p>Pin both ends, aligning tips and aligning the marks between diamond & triangle....</p> 
<p>21</p> <p>Remove from the machine....</p> 	<p>22</p> <p>Align the OTHER triangle tip with the NEXT diamond.</p> 
<p>23</p> <p>Sew the seam down to the pencil mark, stop & back-tack....</p> 	<p>24</p> <p>Align the diamond tips, and fold the triangle between the layers....</p> 

Quick Star Quilts

Assembly tips – Powerpoint screen shots

Sew from the RAW EDGES at the diamond tips down to the marks....

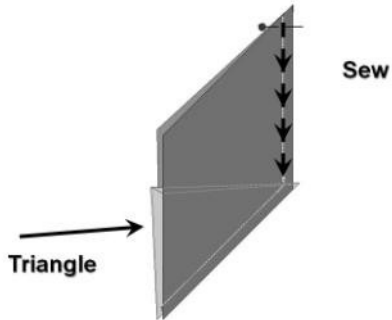

25

Back-stitching or back-tacking at the pin / mark.

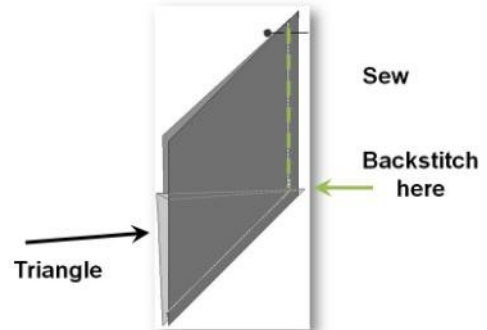

26

Open; press seams toward triangle and open between diamonds.

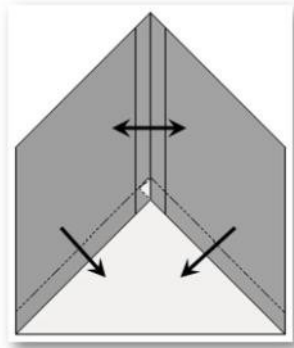

27

Press the "beak" either direction.

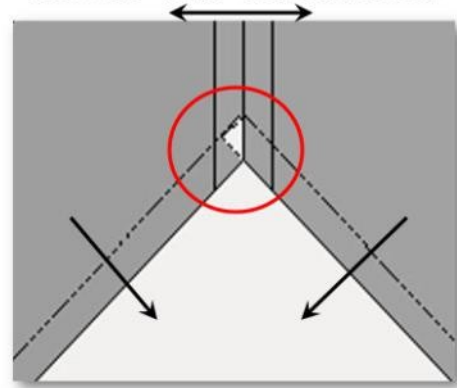

28

Add the next diamond to this unit...
...according to your diagram.

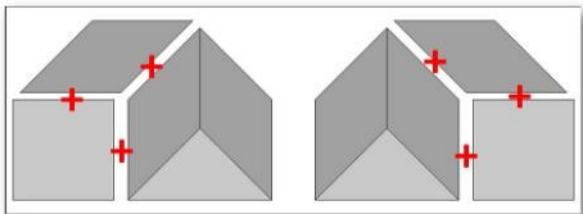

29

...according to your diagram.



30

Quick Star Quilts

Assembly tips – Powerpoint screen shots

...according to your diagram.



31

Lay the diamond/triangle unit face up.

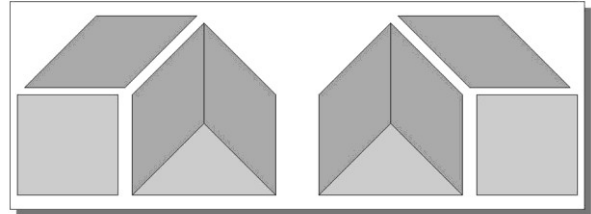

32

Pin, aligning the 1/4" marks.

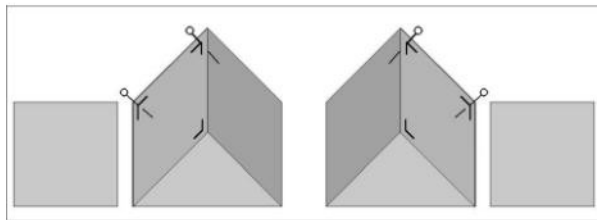

33

Lay the next diamond right sides together, on top of the unit.

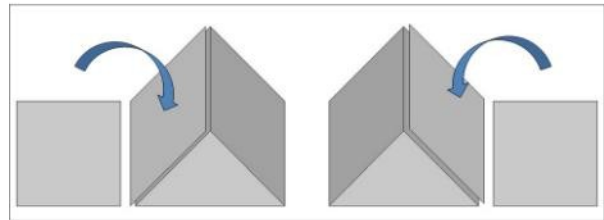

34

Sew between the pins – begin & end with a back-stitch or back-tack.

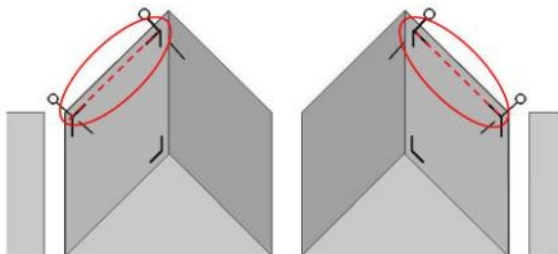

35

Remember – leave seam allowances free if additional pieces will be added.

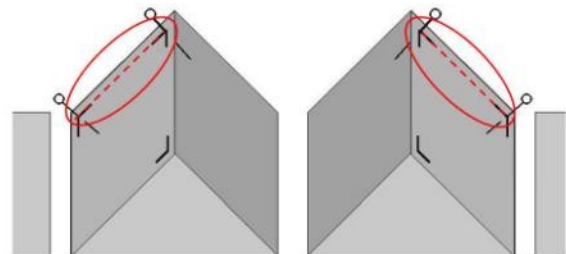

36

Quick Star Quilts

Assembly tips – Powerpoint screen shots

Open the diamond out; press the seam open from the back.

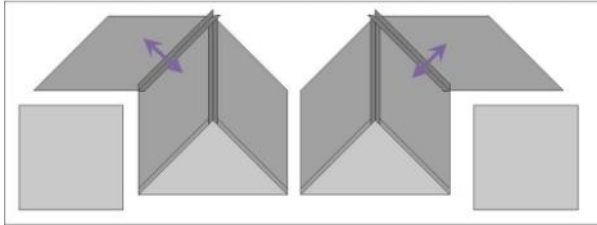

37

Attach the adjacent square to either side of the diamonds.

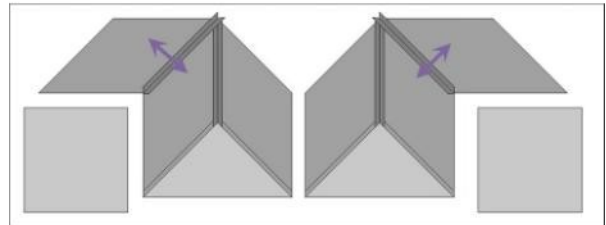

38

Fold the adjacent square right sides together with the diamond.

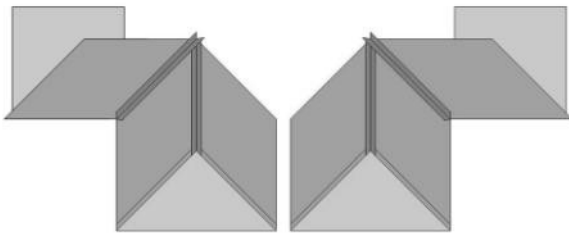

39

Pin, aligning the marks on both pieces.

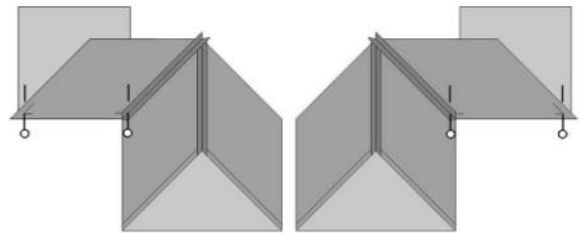

40

Sew between the pins, back-tacking at each end.

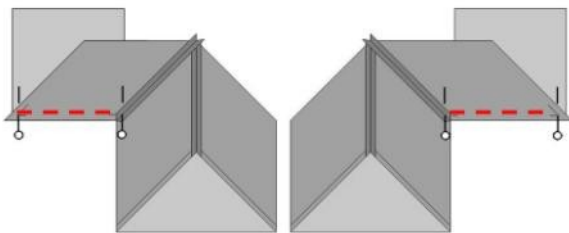

41

Do NOT sew over the seam allowances.

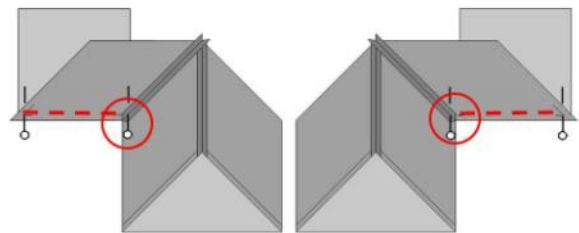

42

Quick Star Quilts

Assembly tips – Powerpoint screen shots

Construct center sections

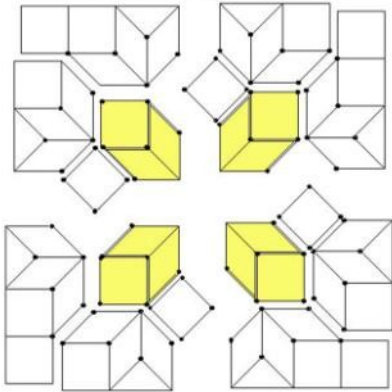

43

These units resemble "Baby's Blocks" units.

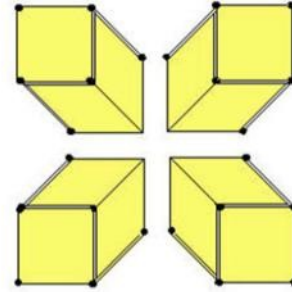

44

You have already created sections somewhat like this.

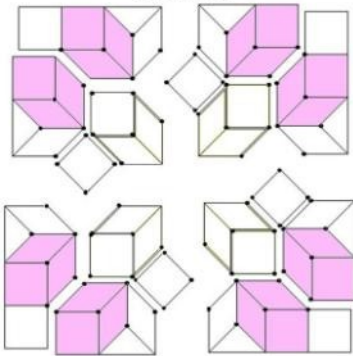

45

Construct sections, gradually joining loose pieces together.

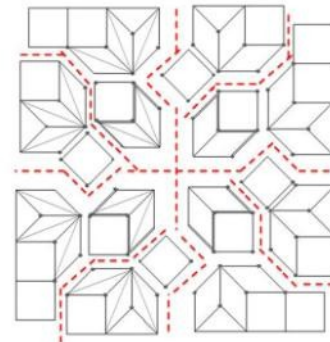

46

Create 1/8 units of the design.

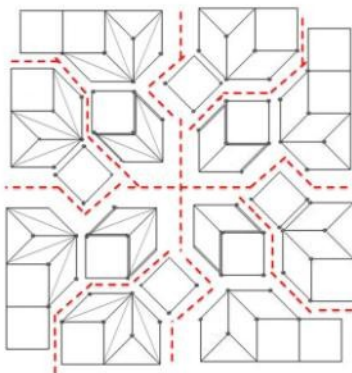

47

Sew eighths together, creating quarters of the design.

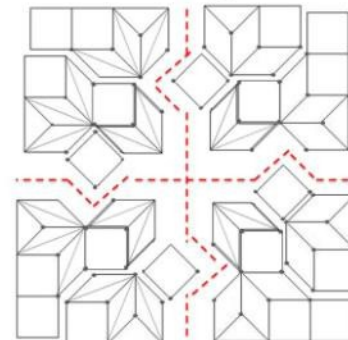

48

Quick Star Quilts

Assembly tips – Powerpoint screen shots

Sew eighths together, creating quarters of the design.

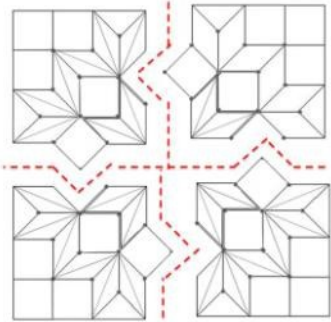

49

The quilt sections have grown larger.



50

Note – this construction is DIFFERENT than the construction diagram....

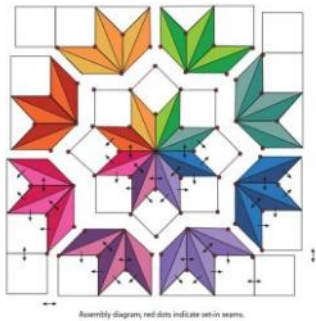

51

....you will construct the center and attached pieces in sections....

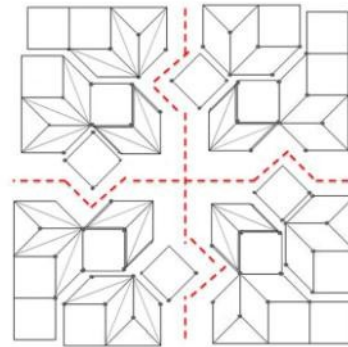

52

....you will construct the center and attached pieces in sections....

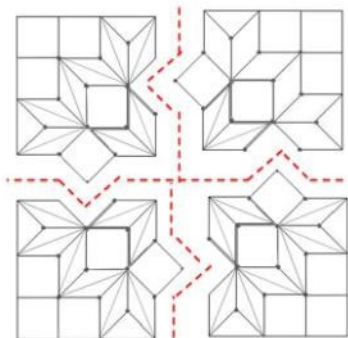

53

Refer to pages 18-21 in the book for tips on the center assembly .



54

Quick Star Quilts

Assembly tips – Powerpoint screen shots

The shapes refer to the *center of the design*—
whether solid or split shapes.....

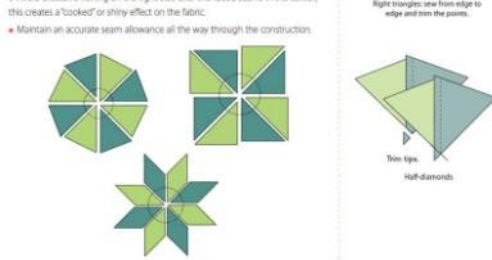

16 Quick Star Quilts & Beyond

55

...the remaining attached sections are
hidden in the illustrations.

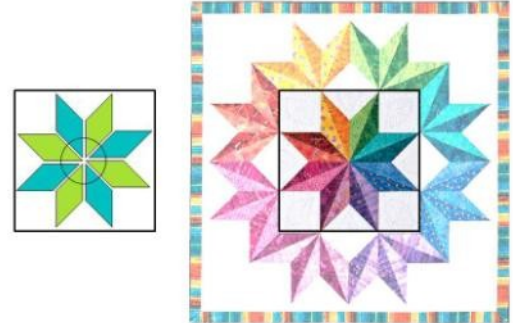

56

...and the center is joined in sections,
step-by-step....

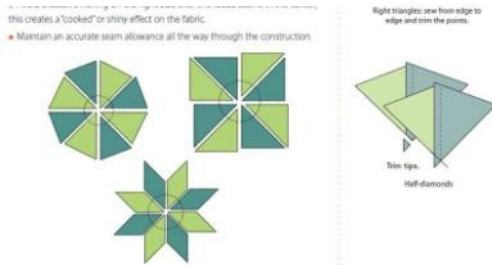

16 Quick Star Quilts & Beyond

57

The center diamonds (and attached
pieced design sections)....

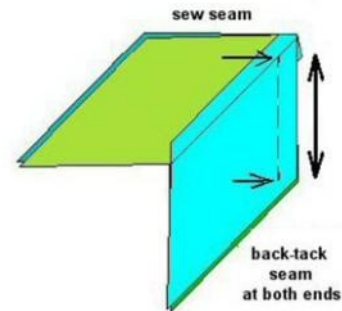

58

....may be joined in two different ways....
METHOD 1:

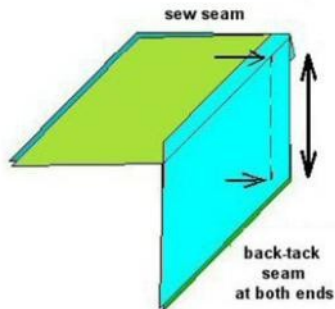

59

Leave center seam allowance free
only when pressing seams to the side.

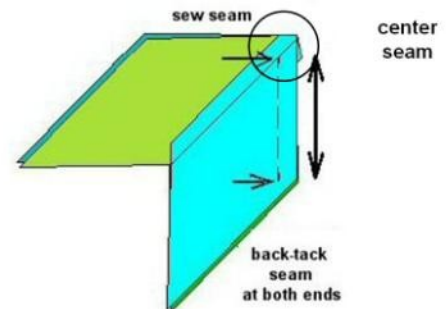

60

Quick Star Quilts

Assembly tips – Powerpoint screen shots

The pressed seams will form a clockwise or counter clockwise pattern.

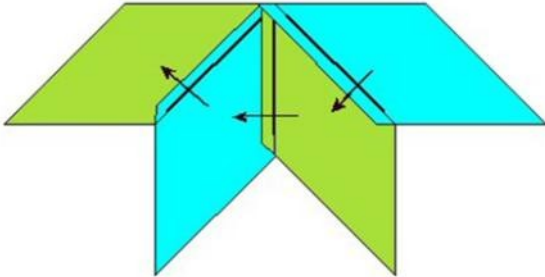

61

When quilt halves are joined, match the centers with a pin.

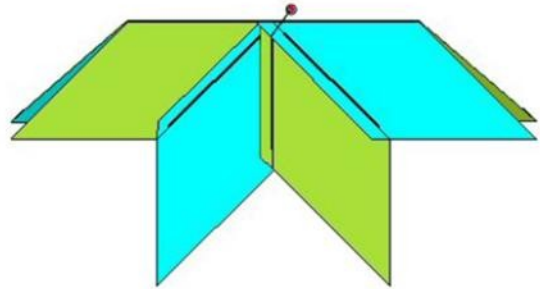

62

Use additional pins to secure the seam. Take 2-3 stitches to baste center.

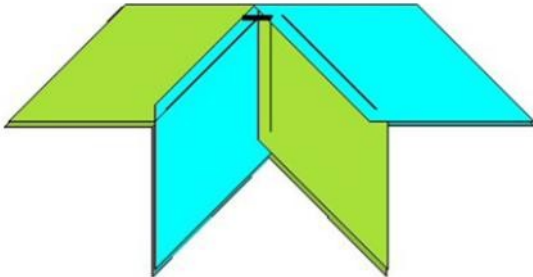

63

If the seams match to your satisfaction, sew from 1/4" mark to mark, backstitching at either end.

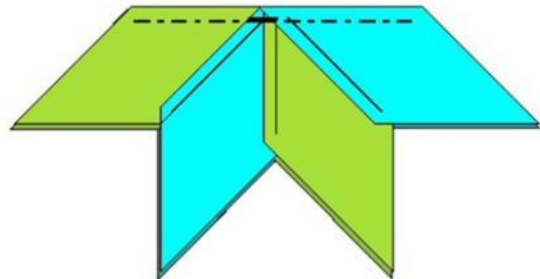

64

Press all the seams, front and back. Note the spiraling pattern on the back.

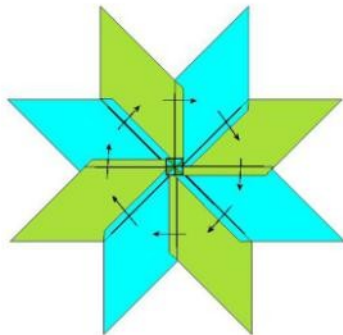

65

Center of star after seams are pressed to the side



66

Quick Star Quilts

Assembly tips – Powerpoint screen shots

Do not iron (rubbing back and forth) as the center of your star will get shiny.

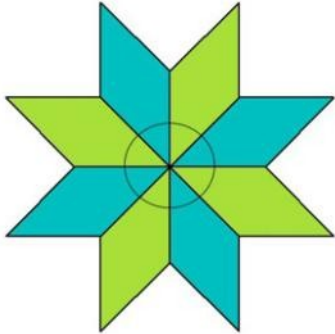

67

Do not iron (rubbing back and forth) as the center of your star will get shiny.

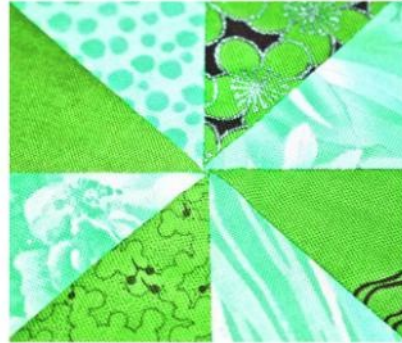

68

Note: Center seam will always be slightly off-set with this method.

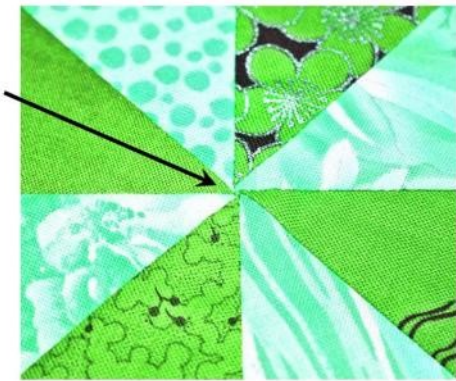

69

Method 2 for center diamonds (and attached pieced design sections).... Begins on pg 20.....

METHOD TWO: SEAMS PRESSED OPEN

This method is very similar to the previous technique but, when properly executed, results in a perfectly aligned center point. As always, *maintain consistent seam allowances* during construction and press seams open carefully for success. A diamond is used in the illustrations, but the process is the same for other shapes.

70

Method 2 for center diamonds (and attached pieced design sections)....

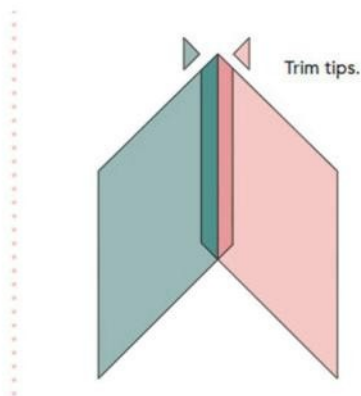

71

Align two quarter units at the center seam.
Pin securely.....

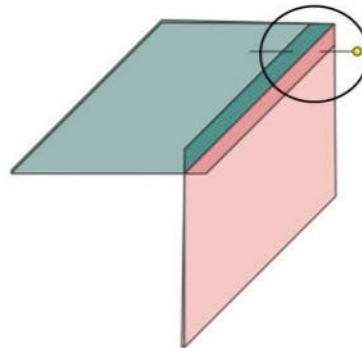

72

Quick Star Quilts

Assembly tips – Powerpoint screen shots

Sew from raw edge at center.... And backstitch at the ¼" mark....

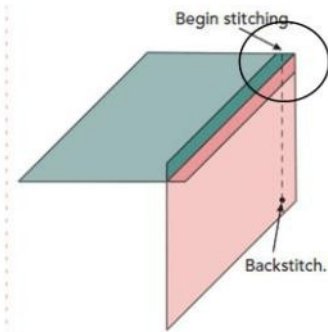

73

Sew from raw edge at center.... And backstitch at the ¼" mark....

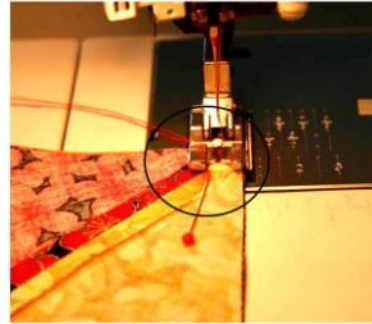

74

When seams are pressed open, sew from the seam allowances here.



75

Open the new half star unit. Press center seam open.

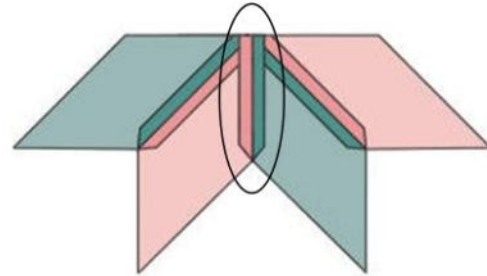

76

Open the new half star unit. Press center seam open.



77

Open the new half star units.

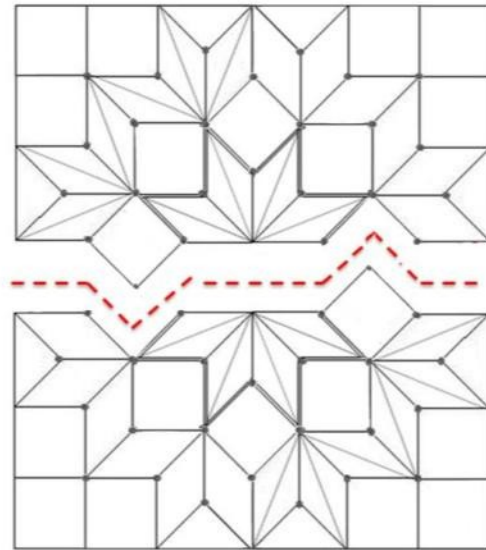

78

Quick Star Quilts

Assembly tips – Powerpoint screen shots

Press. Flip one unit right side together with the other unit..

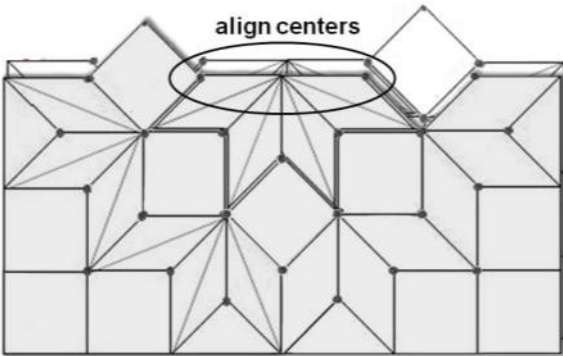

79

two half stars

**Align two half star units at the center seam.
Pin. Baste 3-5 stitches.**

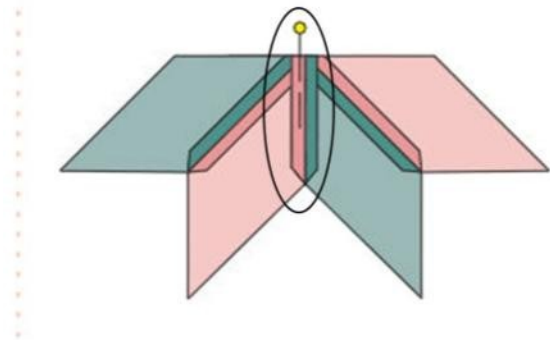

80

**Baste 3-5 stitches.
Open and check for alignment.**

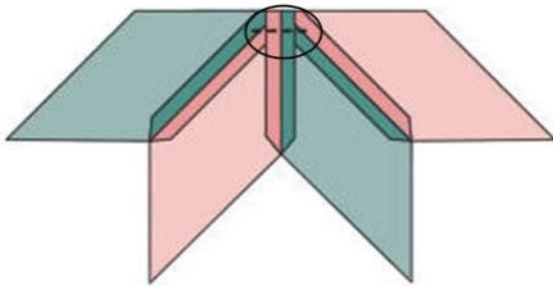

81

Open and check for alignment.



82

**Sew the seam, edge-to-edge.
Backstitch at both ends.**

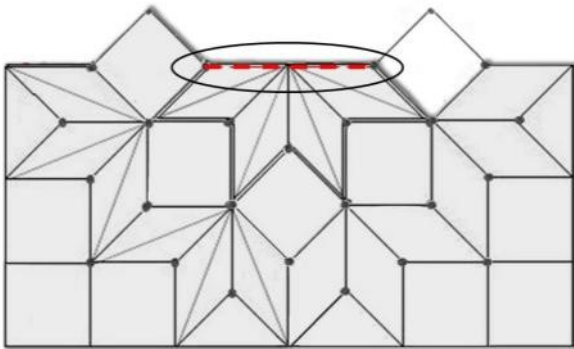

83

Press the seams open.



84

Quick Star Quilts

Assembly tips – Powerpoint screen shots

Do not iron over the raised center.



85

Continue:

- Matching the short segments,
- pinning and sewing between the marks,
- back stitching at both ends.
- Press as you work. Complete the top.

86

Next: Borders